



Cisco Firepower 1010 Series Hardware Installation Guide

First Published: 2019-07-24

Last Modified: 2023-03-22

Americas Headquarters

Cisco Systems, Inc.
170 West Tasman Drive
San Jose, CA 95134-1706
USA
<https://www.cisco.com>
Tel: 408 526-4000
800 553-NETS (6387)
Fax: 408 527-0883

THE SPECIFICATIONS AND INFORMATION REGARDING THE PRODUCTS IN THIS MANUAL ARE SUBJECT TO CHANGE WITHOUT NOTICE. ALL STATEMENTS, INFORMATION, AND RECOMMENDATIONS IN THIS MANUAL ARE BELIEVED TO BE ACCURATE BUT ARE PRESENTED WITHOUT WARRANTY OF ANY KIND, EXPRESS OR IMPLIED. USERS MUST TAKE FULL RESPONSIBILITY FOR THEIR APPLICATION OF ANY PRODUCTS.

THE SOFTWARE LICENSE AND LIMITED WARRANTY FOR THE ACCOMPANYING PRODUCT ARE SET FORTH IN THE INFORMATION PACKET THAT SHIPPED WITH THE PRODUCT AND ARE INCORPORATED HEREIN BY THIS REFERENCE. IF YOU ARE UNABLE TO LOCATE THE SOFTWARE LICENSE OR LIMITED WARRANTY, CONTACT YOUR CISCO REPRESENTATIVE FOR A COPY.

The Cisco implementation of TCP header compression is an adaptation of a program developed by the University of California, Berkeley (UCB) as part of UCB's public domain version of the UNIX operating system. All rights reserved. Copyright © 1981, Regents of the University of California.

NOTWITHSTANDING ANY OTHER WARRANTY HEREIN, ALL DOCUMENT FILES AND SOFTWARE OF THESE SUPPLIERS ARE PROVIDED "AS IS" WITH ALL FAULTS. CISCO AND THE ABOVE-NAMED SUPPLIERS DISCLAIM ALL WARRANTIES, EXPRESSED OR IMPLIED, INCLUDING, WITHOUT LIMITATION, THOSE OF MERCHANTABILITY, FITNESS FOR A PARTICULAR PURPOSE AND NON-INFRINGEMENT OR ARISING FROM A COURSE OF DEALING, USAGE, OR TRADE PRACTICE.

IN NO EVENT SHALL CISCO OR ITS SUPPLIERS BE LIABLE FOR ANY INDIRECT, SPECIAL, CONSEQUENTIAL, OR INCIDENTAL DAMAGES, INCLUDING, WITHOUT LIMITATION, LOST PROFITS OR LOSS OR DAMAGE TO DATA ARISING OUT OF THE USE OR INABILITY TO USE THIS MANUAL, EVEN IF CISCO OR ITS SUPPLIERS HAVE BEEN ADVISED OF THE POSSIBILITY OF SUCH DAMAGES.

Any Internet Protocol (IP) addresses and phone numbers used in this document are not intended to be actual addresses and phone numbers. Any examples, command display output, network topology diagrams, and other figures included in the document are shown for illustrative purposes only. Any use of actual IP addresses or phone numbers in illustrative content is unintentional and coincidental.

All printed copies and duplicate soft copies of this document are considered uncontrolled. See the current online version for the latest version.

Cisco has more than 200 offices worldwide. Addresses and phone numbers are listed on the Cisco website at www.cisco.com/go/offices.

The documentation set for this product strives to use bias-free language. For purposes of this documentation set, bias-free is defined as language that does not imply discrimination based on age, disability, gender, racial identity, ethnic identity, sexual orientation, socioeconomic status, and intersectionality. Exceptions may be present in the documentation due to language that is hardcoded in the user interfaces of the product software, language used based on standards documentation, or language that is used by a referenced third-party product.

Cisco and the Cisco logo are trademarks or registered trademarks of Cisco and/or its affiliates in the U.S. and other countries. To view a list of Cisco trademarks, go to this URL: <https://www.cisco.com/c/en/us/about/legal/trademarks.html>. Third-party trademarks mentioned are the property of their respective owners. The use of the word partner does not imply a partnership relationship between Cisco and any other company. (1721R)

© 2019-2023 Cisco Systems, Inc. All rights reserved.

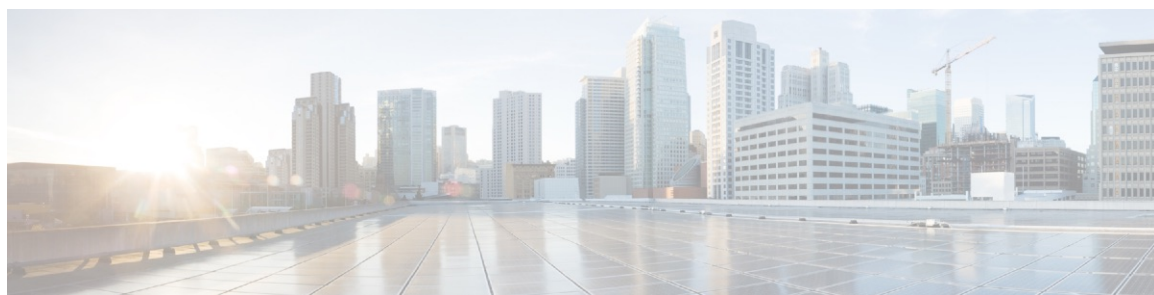

CONTENTS

CHAPTER 1

Overview 1

- Features 1
- Package Contents 8
- QR Code Sticker 9
- Serial Number and Digital Documentation Portal QR Code 10
- Front Panel 11
- Rear Panel 11
- Status LEDs 12
- Hardware Specifications 14
- Product ID Numbers 15
- Power Cord Specifications 16

CHAPTER 2

Installation Preparation 23

- Installation Warnings 23
- Position the Chassis 25
- Safety Recommendations 26
- Maintain Safety with Electricity 27
- Prevent ESD Damage 27
- Site Environment 27
- Site Considerations 28
- Power Supply Considerations 28
- Rack Configuration Considerations 29

CHAPTER 3

Mount the Chassis 31

- Unpack and Inspect the Chassis 31
- Desktop-Mount the Chassis 32

Wall-Mount the Chassis 32

Rack-Mount the Chassis 35

CHAPTER 4 **Connect to the Console Port 41**

Connect to the Console Port with Microsoft Windows 41

Connect to the Console Port with Mac OS X 43

Connect to the Console Port with Linux 43

CHAPTER 5 **Installation, Maintenance, and Upgrade 45**

Install the FIPS Opacity Shield 45



CHAPTER 1

Overview

- [Features, on page 1](#)
- [Package Contents, on page 8](#)
- [QR Code Sticker, on page 9](#)
- [Serial Number and Digital Documentation Portal QR Code, on page 10](#)
- [Front Panel, on page 11](#)
- [Rear Panel, on page 11](#)
- [Status LEDs, on page 12](#)
- [Hardware Specifications, on page 14](#)
- [Product ID Numbers, on page 15](#)
- [Power Cord Specifications, on page 16](#)

Features

The Cisco Firepower 1010 and 1010E are a series of compact network security appliances in the Cisco Firepower family. The Firepower 1010 is first supported in Firepower Threat Defense (FTD) Version 6.4 and ASA Version 9.12. PoE+ and L2 switch support were added beginning with FTD Version 6.5 and ASA Version 9.13. The 1010E without PoE+ is supported first in Secure Firewall Threat Defense Version 7.2.3 and Secure Firewall ASA Version 9.18.2.

See the [Cisco Firepower Compatibility Guide](#), which provides Cisco Firepower software and hardware compatibility, including operating system and hosting environment requirements, for each supported Firepower version.

See [Product ID Numbers, on page 15](#) for a list of the product IDs (PIDs) associated with the Firepower 1010 and 1010E.

The following figure shows the Cisco Firepower 1010 and 1010E.

Figure 1: Cisco Firepower 1010 and 1010E



The following table lists the features for the Firepower 1010 and 1010E.

Table 1: Firepower 1010 and 1010E Features

Feature	1010	1010E
Security standards certifications		—

Feature	1010	1010E
	<ul style="list-style-type: none"> • Certified on ASA 9.16.x: <ul style="list-style-type: none"> • Common Criteria Certification for the Network Device Collaborative Protection Profile (NDcPPv2.2E) • Firewall Collaborative Protection Profile Module (FW_MOD_v1.4e) • Virtual Private Network Gateway Protection Profile Module (VPNGW_MOD_v1.1) • Certified on FTD 6.4.x and FX-OS 2.6.x: <ul style="list-style-type: none"> • Common Criteria Certification for the Network Device Collaborative Protection Profile (NDcPPv2.2E) • IPS Extended Package (IPSEP v2.11) • Firewall Collaborative Protection Profile Module (MOD_FW_v1.4e) • Virtual Private Network Gateway Protection Profile Module (MOD_VPNGW_v1.1) • Federal Information Processing Standards (FIPS) 140-2 on FTD 6.4.x and FX-OS 2.6.x • Department of Defense Information Network Approved Product List (DoDIN APL) • US Government Compliance for IPv6 (USGv6) on FTD 7.0.x— Certification Approval 	

Feature	1010	1010E
	<p>under the R1 Profile for the Product Classification “NPP.”</p> <p>See the "Security Certifications Compliance" topic in the "Appliance Platform Settings" chapter in your software version of the configuration guide for the instructions on how to enable security certifications compliance.</p>	
Form factor	1 RU	
Mounting	Desktop mount Wall mount (Cisco part number 69-100647-01) Rack mount (Cisco part number 800-107605-01)	
Airflow	Side-to-side No fan Note Because the Firepower 1010 and 1010E have no fan, the internal system temperature is significantly higher than the ambient temperature cited in Hardware Specifications, on page 14 .	
Processor	One 4-core Intel CPU	
Memory	8-GB DDR4 DRAM	
Boot partition	8 GB (internal)	
L2 switch	Marvell SOHO 88E6390 Note First supported in FTD Version 6.5 and ASA Version 9.13	Not supported
Management port	One Gigabit Ethernet RJ-45 10/100/1000 BaseT Restricted to network management access; connect with an RJ-45 cable	
Console port	One RJ-45 Use to access management through an external system	
USB Mini B port	One USB Mini B Use to access management through an external system	
USB port	One USB 3.0 Type A Use to attach an external device such as storage	

Feature	1010	1010E
Network ports	<p>Eight Gigabit Ethernet RJ-45 10/100/1000 BaseT</p> <p>Each RJ-45 (8P8C) copper port supports auto Medium Dependent Interface Crossover (MDI/X) as well as auto-negotiation for interface speed, duplex, and other negotiated parameters, and are MDI/X-compliant.</p> <p>The ports are numbered (from top to bottom, left to right) 1, 2, 3, 4, 5, 6, 7, 8. Each port includes a pair of LEDs, one each for connection status and link status. The ports are named and numbered Gigabit Ethernet 1/1 through Gigabit Ethernet 1/8.</p> <p>Note You can use ports 7 and 8 as PoE+ ports. PoE+ is first supported in FTD Version 6.5 and ASA Version 9.13.</p>	<p>Eight Gigabit Ethernet RJ-45 10/100/1000 BaseT</p> <p>Each RJ-45 (8P8C) copper port supports auto Medium Dependent Interface Crossover (MDI/X) as well as auto-negotiation for interface speed, duplex, and other negotiated parameters, and are MDI/X-compliant.</p> <p>The ports are numbered (from top to bottom, left to right) 1, 2, 3, 4, 5, 6, 7, 8. Each port includes a pair of LEDs, one each for connection status and link status. The ports are named and numbered Gigabit Ethernet 1/1 through Gigabit Ethernet 1/8.</p>
PoE+ controller card	<p>Note Ports 7 and 8 are PoE+ ports; first supported in FTD Version 6.5 and ASA Version 9.13.</p>	Not supported
Lock slot	Accepts a standard Kensington T-bar locking mechanism for securing the chassis	
Reset button	A small recessed button that if pressed for longer than three seconds resets the chassis to its default state following the next reboot. Configuration variables are reset to factory default, but the flash is not erased and no files are removed.	
Power switch	No System power is controlled by the power cord; there is no power button. To shut down the Firepower 1010 or 1010E, remove the AC power supply.	
Power cord socket	The chassis is powered on when you plug in the AC power supply.	

Feature	1010	1010E
AC power supply	<p>One external AC power supply</p> <p>The power supply has a total of 115 W of power. There is 55 W of +12-V system power and 60 W of -53.5-V PoE+ power.</p> <p>Note PoE+ is first supported in FTD Version 6.5 and ASA Version 9.13.</p> <p>Note Use the power supply (part number 341-100765-01) that shipped with the chassis. It supports PoE+.</p>	<p>One external AC power supply</p> <p>The power supply has a total of 115 W of power. There is 55 W of +12-V system power.</p> <p>Note Use the power supply (part number 341-100765-01) that shipped with the chassis.</p>
Storage	<p>One 200-GB M.2 SATA SSD drive</p> <p>The drive is used by the software; there is no user access to the drive.</p> <p>The drive is not field-replaceable; you must return the chassis to Cisco for drive replacement.</p>	
Rubber feet	<p>Four rubber feet on the bottom of the chassis</p> <p>Note The rubber feet are needed for proper cooling. Do not remove them.</p>	

Console Ports

The Firepower 1010 and 1010E have two external console ports, a standard RJ-45 port and a USB Mini B serial port. Only one console port can be active at a time. When a cable is plugged into the USB console port, the RJ-45 port becomes inactive. Conversely, when the USB cable is removed from the USB port, the RJ-45 port becomes active. The console ports do not have any hardware flow control. You can use the CLI to configure the chassis through either serial console port by using a terminal server or a terminal emulation program on a computer.

- RJ-45 (8P8C) port—Supports RS-232 signaling to an internal UART controller. The RJ-45 console port does not support a remote dial-in modem. You can use a standard management cable (Cisco part number 72-3383-01) to convert the RJ45-to-DB9 connection if necessary.
- USB Mini B port—Lets you connect to a USB port on an external computer. For Linux and Macintosh systems, no special driver is required. For Windows systems, you must download and install a USB driver (available on software.cisco.com). You can plug and unplug the USB cable from the console port without affecting Windows HyperTerminal operations. We recommend shielded USB cables with properly terminated shields. Baud rates for the USB console port are 1200, 2400, 4800, 9600, 19200, 38400, 57600, and 115200 bps.



Note For Windows operating systems, you must install a Cisco Windows USB Console Driver on any PC connected to the console port before using the USB console port. See [Connect to the Console Port with Microsoft Windows, on page 41](#) for information on installing the driver.

External Flash Storage

The chassis contains a standard USB Type A port that you can use to attach an external device. The USB port can provide output power of 5 V and up to a maximum of 1A (5 USB power units).

- External USB drive (optional)—You can use the external USB Type A port to attach a data-storage device. The external USB drive identifier is *disk1*. When the chassis is powered on, a connected USB drive is mounted as *disk1* and is available for you to use. Additionally, the file-system commands that are available to *disk0* are also available to *disk1*, including **copy**, **format**, **delete**, **mkdir**, **pwd**, **cd**, and so on.
- FAT-32 File System—The Firepower 1010 only supports FAT-32-formatted file systems for the external USB drive. If you insert an external USB drive that is not in FAT-32 format, the system mounting process fails, and you receive an error message. You can enter the command **format disk1**: to format the partition to FAT-32 and mount the partition to *disk1* again; however, data might be lost.

Package Contents

The following figure shows the package contents for the Firepower 1010 and 1010E. Note that the contents are subject to change and your exact contents might contain additional or fewer items.

Figure 2: Firepower 1010 and 1010E Package Contents

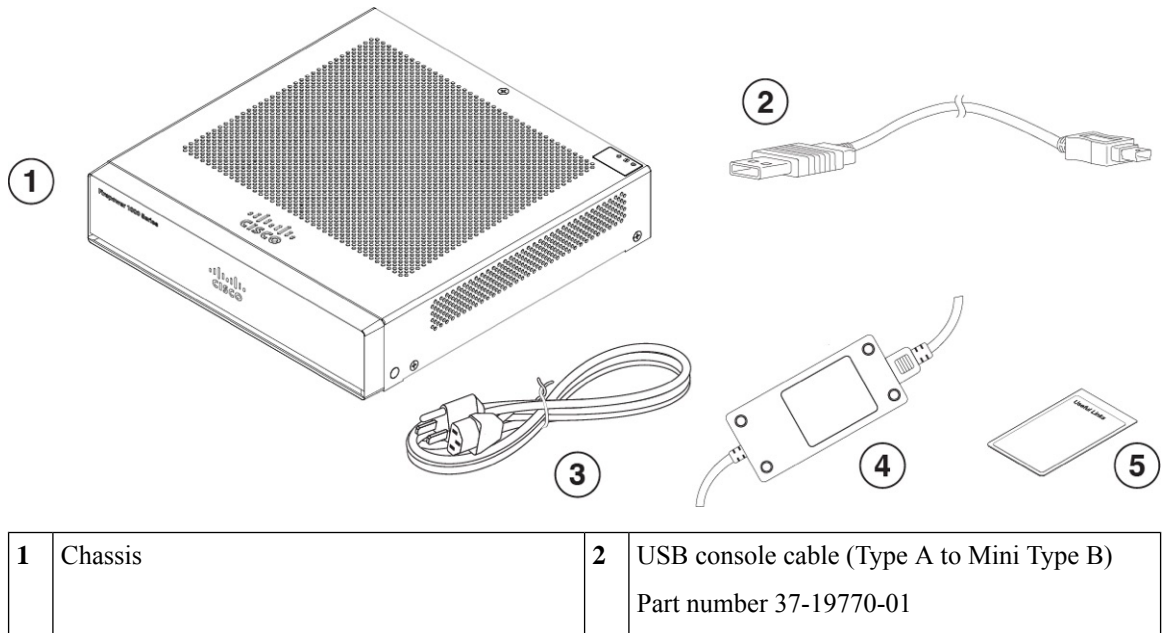

3	Power cord See Power Cord Specifications, on page 16 for a list of the approved power cords.	4	Power supply
5	<i>Cisco Secure Firepower 1010</i> This document has a URL and QR code that point to the Digital Documentation Portal. The portal contains links to the Product Information page, the Hardware Installation Guide, the Regulatory and Safety Information Guide, the Getting Started Guide, and the Easy Deployment Guide.		—

QR Code Sticker

The QR code sticker on the rear panel of the chassis points to the [Easy Deployment Guide for Cisco Secure Firewall 1000, 2100, and 3100 Series](#) that explains low touch provisioning (LTP). LTP allows anyone to connect a new Firepower 1010 to a network so that the IT department can onboard the device to CDO and configure it remotely. CDO supports Firepower Threat Defense (FTD) version 6.7 and later.

The following figure shows the QR code sticker.

Figure 3: QR Code Sticker



The following figure shows the placement of the QR code sticker on the rear panel of the chassis.

Figure 4: Firepower 1010 QR Code Sticker

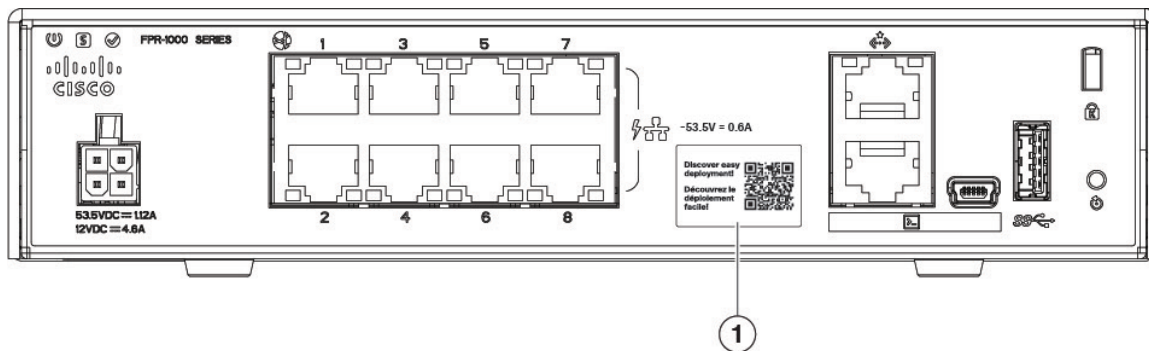

1	QR code sticker	
---	-----------------	--

Serial Number and Digital Documentation Portal QR Code

The compliance label on the bottom of the chassis contains the chassis serial number, regulatory compliance marks, and the Digital Documentation Portal QR code that points to the getting started guide, the regulatory and compliance guide, the easy deployment guide, and the hardware installation guide.

The following figure shows an example compliance label found on the bottom of the chassis.

Figure 5: Compliance Label on the Chassis

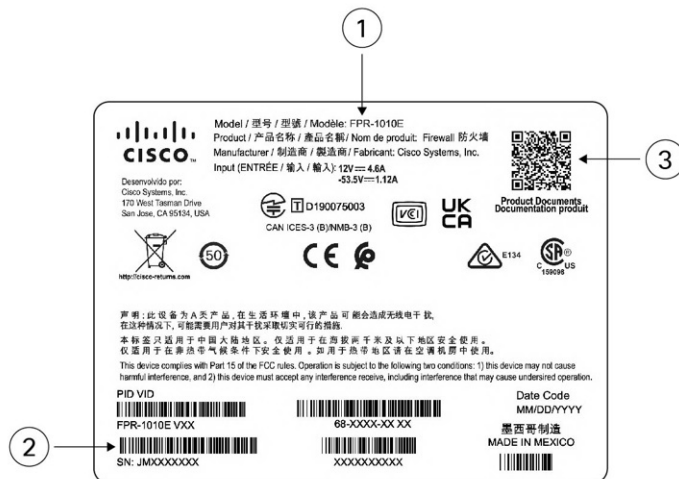

1	Chassis model number	2	Chassis serial number
3	Digital Documentation Portal QR code		—

Front Panel

The following figure shows the front panel of the Firepower 1010 and 1010E. Note that there are no connectors or LEDs on the front panel.

Figure 6: Firepower 1010 and 1010E Front Panel



Rear Panel

The following figure shows the rear panel of the Firepower 1010 and 1010E. See [Status LEDs, on page 12](#) for a description of the LEDs.

Figure 7: Firepower 1010 and 1010E Rear Panel

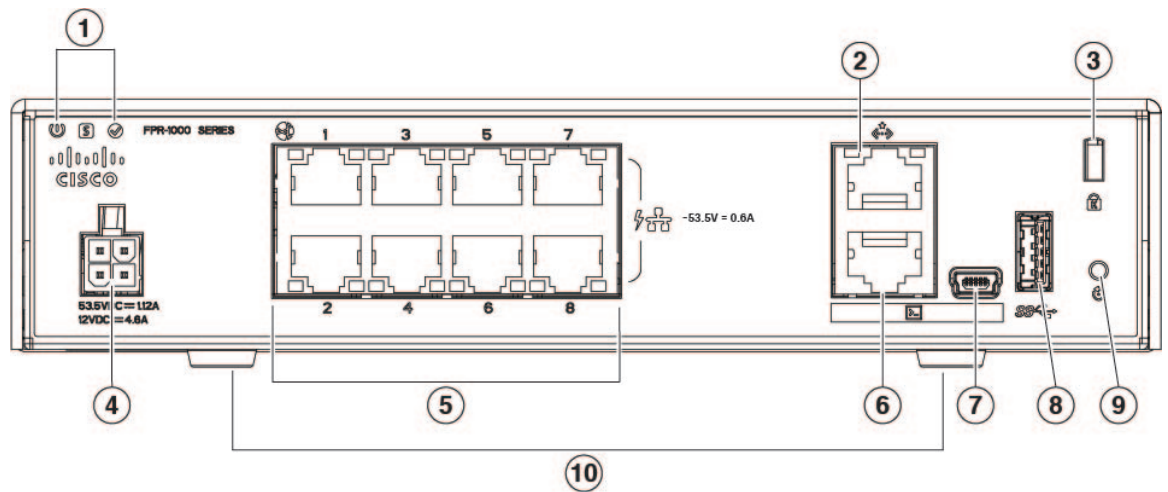

1	Status LEDs	2	Management port
3	Lock slot	4	Power cord socket
5	Network data ports	6	Console port
7	USB Mini B port	8	USB Type A port
9	Reset button	10	Rubber feet

Status LEDs

Facing the rear of the chassis, the LEDs are located on the top left edge (facing the front of the chassis, they are in the back right corner of the top). The network port LEDs are at the top sides of each network port.

The following figure shows the status LEDs on the rear panel and on the cover of the chassis.

Figure 8: Status LEDs

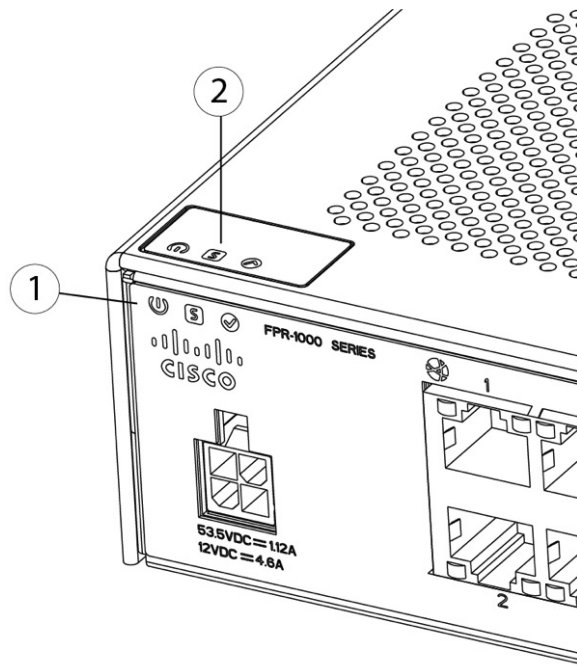

1	Power, Status, and Active LEDs on rear of chassis	2	Power, Status, and Active LEDs on top of chassis
---	---	---	--

The following figure shows all of the LEDs on the rear panel of the Firepower 1010 and 1010E and describes their states.

Figure 9: Rear Panel LEDs

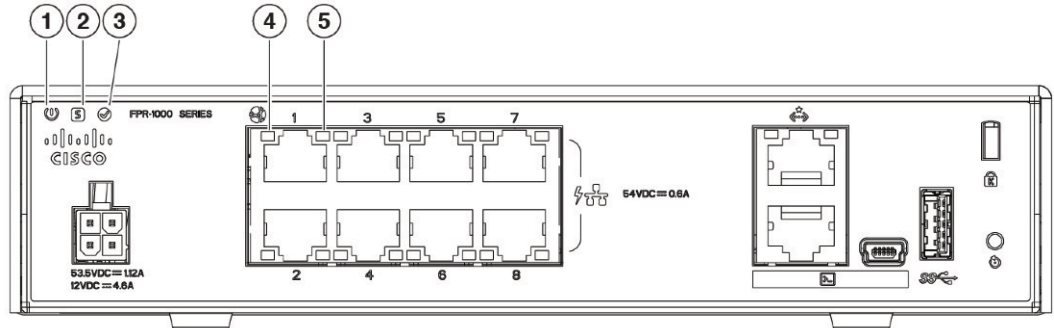

<p>1 Power</p> <p>Power supply status:</p> <ul style="list-style-type: none"> • Off—Power supply off. • Green—Power supply on. 	<p>2 Status</p> <p>System operating status:</p> <ul style="list-style-type: none"> • Off—System has not booted up yet. • Green, flashing quickly—System is booting up. • Green—Normal system function. • Amber—Critical alarm indicating one or more of the following: <ul style="list-style-type: none"> • Major failure of a hardware or software component. • Over-temperature condition. • Power voltage outside the tolerance range. • Green, flashing slowly (twice in 5 seconds)—Cloud connected. <p>Note Cisco Defense Orchestrator (CDO) is valid for FTD 6.7 and later.</p> <ul style="list-style-type: none"> • Green and amber, flashing—Cloud connection failure. • Green—Cloud disconnected. <p>Note The CDO LED pattern applies to low touch provisioning (LTP). See the Easy Deployment Guide for Cisco Secure Firewall 1000, 2100, and 3100 Series for more information.</p>
---	---

<p>3 Active</p> <p>Status of the failover pair:</p> <ul style="list-style-type: none"> • Off—Failover is not operational. • Green—Failover pair operating normally. The LED is green always unless the chassis is in a high availability pair. • Amber—When the chassis is in a high availability pair, the LED is amber for the standby unit. 	<p>4 Network</p> <p>Status of the network ports.</p> <p>Link status (L):</p> <ul style="list-style-type: none"> • Off—No link, or port is not in use. • Green—Link established. • Green, flashing—Link activity.
<p>5 Network</p> <p>Status of the network ports.</p> <p>Connection-speed status (S):</p> <ul style="list-style-type: none"> • Green, flashing—One flash every three seconds = 10 Mbps. • Green, flashing—Two rapid flashes = 100 Mbps. • Green, flashing—Three rapid flashes = 1000 Mbps. 	<p>—</p>

Hardware Specifications

The following table contains hardware specifications for the Firepower 1010 and 1010E.

Table 2: Firepower 1010 and 1010E Hardware Specifications

	1010	1010E
Dimensions (H x W x D)	1.82 x 7.85 x 8.07 inches (4.62 x 19.94 x 20.50 cm)	
Weight	3 lb (1.36 kg)	

	1010	1010E
System power	30 W Not including any PoE devices connected to the chassis. 55 W is the maximum power for the power supply. Note Use the power supply (part number 341-100765-01) that shipped with the chassis. It supports PoE+. Note PoE+ is first supported in FTD Version 6.5 and ASA Version 9.13.	30 W
Temperature	Operating: 32 to 104°F (0 to 40°C) Derate the maximum operating temperature 1.5° C per 1000 ft above sea level. Nonoperating: -13 to 158°F (-25 to 70°C) maximum altitude is 40,000 ft Note Because the Firepower 1010 and 1010E have no fan, the internal system temperature is significantly higher than the operating temperature.	
Humidity	Operating: 90% Nonoperating: 10 to 90%	
Altitude	Operating: 0 to 9843 (3000 m) Nonoperating: 0 to 15,000 ft (4570 m)	
Acoustic noise	0 dBa	

Product ID Numbers

The following table lists the field-replaceable PIDs associated with the Firepower 1010 and 1010E. The spare components are ones that you can order and replace yourself. If any internal components fail, you must get a return material authorization (RMA) for the entire chassis. See the [Cisco Returns Portal](#) for more information.



Note See the **show inventory** command in the [Cisco Firepower Threat Defense Command Reference](#) or the [Cisco ASA Series Command Reference](#) to display a list of the PIDs for your Firepower 1010 and 1010E.

Table 3: Firepower 1010 and 1010E PIDs

PID	Description
FPR1010-ASA-K9	Cisco Firepower 1010 ASA desktop appliance
FPR1010E-ASA-K9	Cisco Firepower 1010E ASA desktop appliance
FPR1010-NGFW-K9	Cisco Firepower 1010 NGFW desktop appliance
FPR1010E-NGFW-K9	Cisco Firepower 1010E NGFW desktop appliance
FPR1K-DT-ACY-KIT	Cisco Firepower 1010 and 1010E accessory kit
FPR1K-DT-PWR-AC	Cisco Firepower 1010 and 1010E 150-W power supply
FPR1K-DT-PWR-AC=	Cisco Firepower 1010 and 1010E 150-W power supply (spare)
FPR1K-DT-RACK-MNT=	Cisco Firepower 1010 and 1010E rack-mount kit (spare)
FPR1K-DT-WALL-MNT=	Cisco Firepower 1010 and 1010E wall-mount kit (spare)
FPR1K-DT-FIPS-KIT=	Cisco Firepower 1010 FIPS kit (spare)

Power Cord Specifications

Each power supply has a separate power cord. Standard power cords or jumper power cords are available for connection to the security appliance. The jumper power cords for use in racks are available as an optional alternative to the standard power cords.

If you do not order the optional power cord with the system, you are responsible for selecting the appropriate power cord for the product. Using an incompatible power cord with this product may result in electrical safety hazard. Orders delivered to Argentina, Brazil, and Japan must have the appropriate power cord ordered with the system.



Note Only the approved power cords or jumper power cords provided with the chassis are supported.

The following power cords are supported.

Figure 10: Argentina (CAB-AC-C5-ARG)

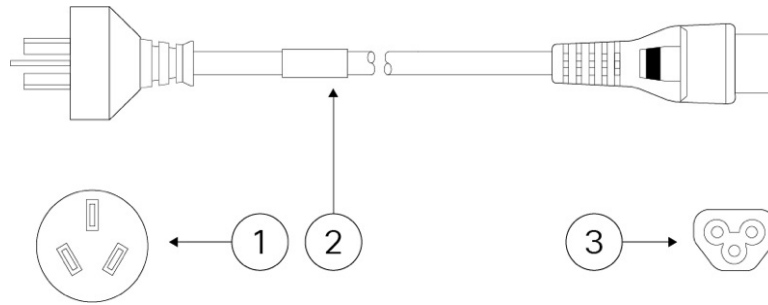

1	Plug: IRAM 2073	2	Cord set rating: 2.5 A, 250 V
3	Connector: IEC 60320/C5		—

Figure 11: Australia (CAB-AC-C5-AUS)

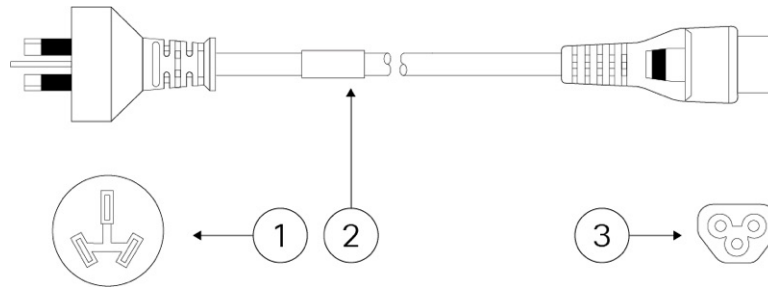

1	Plug: AUS 10S3	2	Cord set rating: 2.5 A, 250 V
3	Connector: IEC 60320/C5		—

Figure 12: Brazil (CAB-AC-C5-BRA)

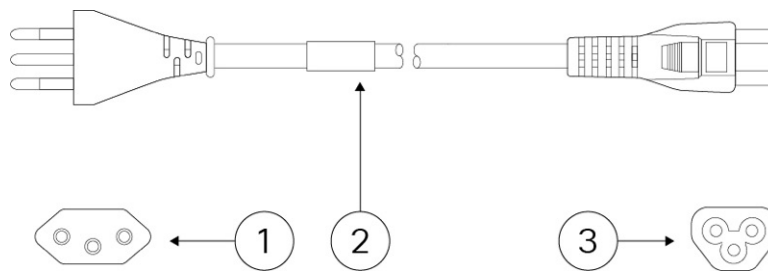

1	Plug: NBR 14136	2	Cord set rating: 2.5 A, 250 V
3	Connector: IEC 60320/C5		—

Figure 13: Canada (CAB-AC-C5)

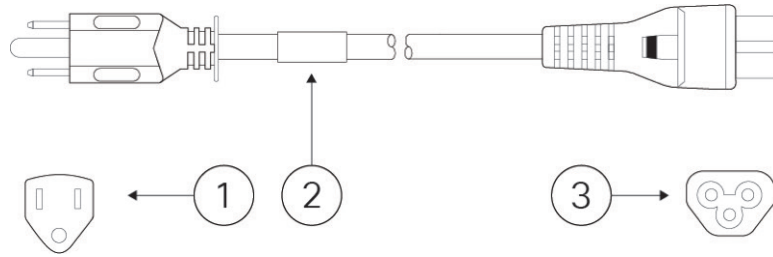

1	Plug: NEMA 5-15P	2	Cord set rating: 2.5 A, 125 V
3	Connector: IEC 60320/C5		—

Figure 14: China (CAB-AC-C5-CHI)

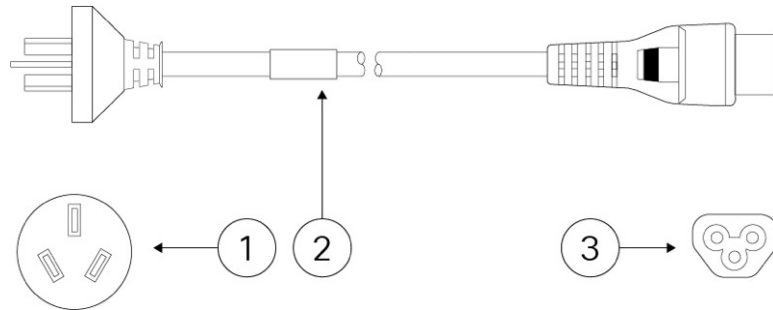

1	Plug: GB 2099.1	2	Cord set rating: 2.5 A, 250 V
3	Connector: IEC 60320/C5		—

Figure 15: Europe (CAB-AC-C5-EUR)

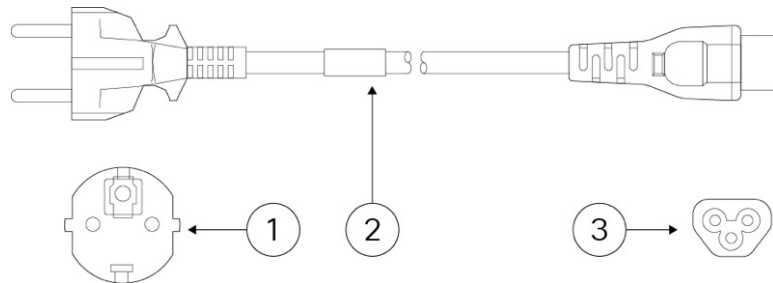

1	Plug: CEE 7 VII	2	Cord set rating: 2.5 A, 250 V
3	Connector: IEC 60320/C5		—

Figure 16: India (CAB-AC-C5-IND)

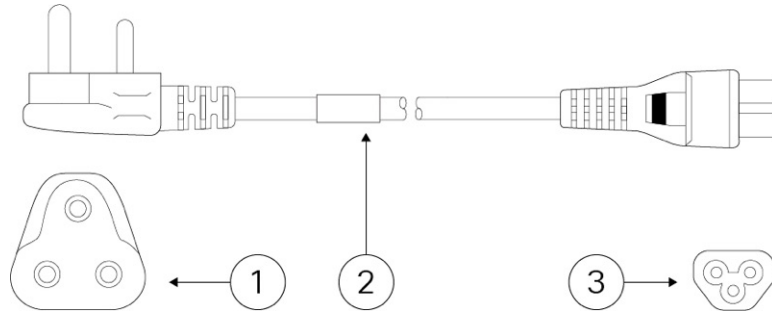

1	Plug: IS 1293	2	Cord set rating: 2.5 A, 250 V
3	Connector: IEC 60320/C5		—

Figure 17: Italy (CAB-AC-C5-ITA)

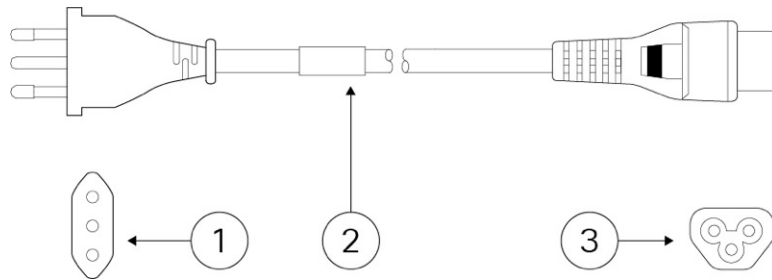

1	Plug: CEI 23-06/VII	2	Cord set rating: 2.5 A, 250 V
3	Connector: IEC 60320/C5		—

Figure 18: Japan (CAB-AC-C5-JAP)

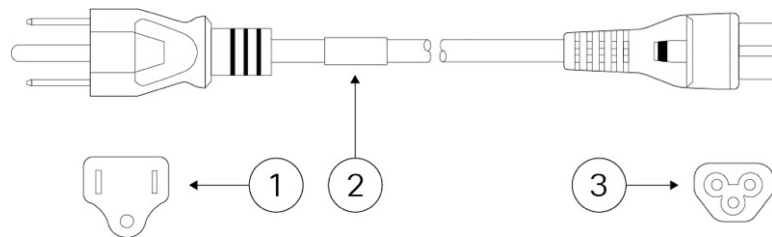

1	Plug: JIS C8303	2	Cord set rating: 3 A, 125 V
3	Connector: IEC 60320/C5		—

Figure 19: Korea (CAB-AC-C5-KOR)

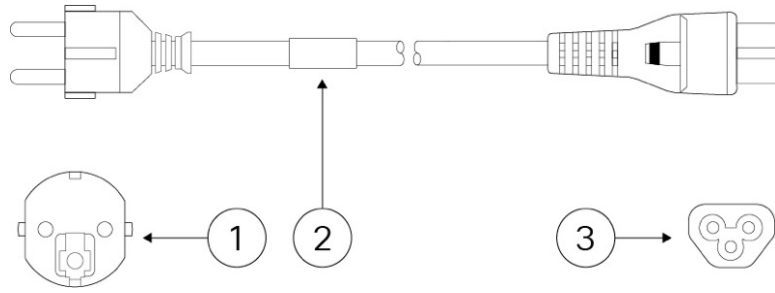

1	Plug: KSC 83205	2	Cord set rating: 3.0 A, 250 V
3	Connector: IEC 60320/C5		—

Figure 20: South Africa (CAB-AC-C5-SAF)

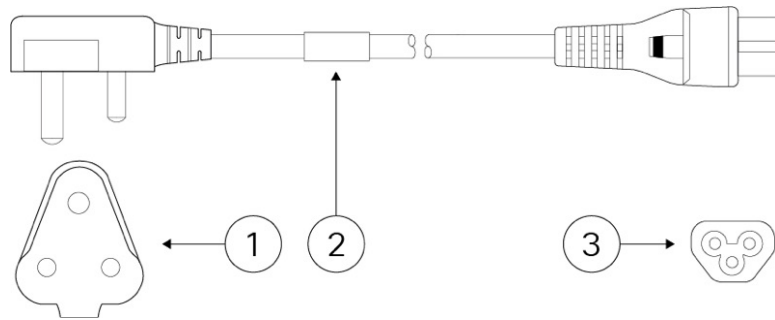

1	Plug: SABS 164-1	2	Cord set rating: 2.5 A, 250 V
3	Connector: IEC 60320/C5		—

Figure 21: Switzerland (CAB-AC-C5-SWI)

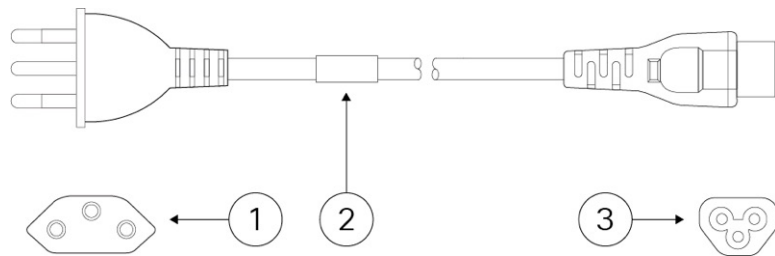

1	Plug: SEV 1011	2	Cord set rating: 2.5 A, 250 V
3	Connector: IEC 60320/C5		—

Figure 22: Taiwan (CAB-AC-C5-TWN)

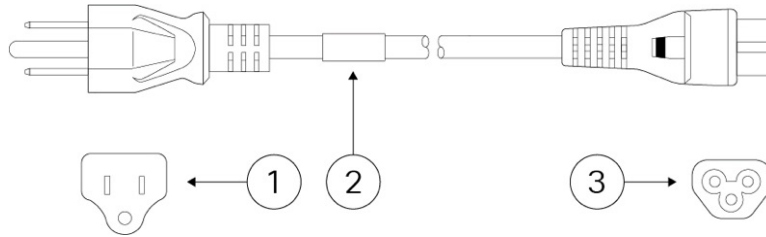

1	Plug: CNS 10917-2	2	Cord set rating: 2.5 A, 125 V
3	Connector: IEC 60320/C5		

Figure 23: United Kingdom (CAB-AC-C5-UK)

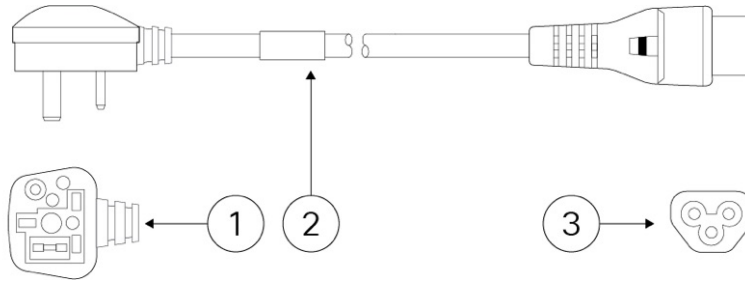

1	Plug: BS1363A/SS145	2	Cord set rating: 2.5 A, 250 V
3	Connector: IEC 60320/C5		—



CHAPTER 2

Installation Preparation

- [Installation Warnings, on page 23](#)
- [Position the Chassis, on page 25](#)
- [Safety Recommendations, on page 26](#)
- [Maintain Safety with Electricity, on page 27](#)
- [Prevent ESD Damage, on page 27](#)
- [Site Environment, on page 27](#)
- [Site Considerations, on page 28](#)
- [Power Supply Considerations, on page 28](#)
- [Rack Configuration Considerations, on page 29](#)

Installation Warnings

Read the [Regulatory and Compliance Information](#) document before installing the chassis.

Take note of the following warnings:



Warning **Statement 1071**—Warning Definition

IMPORTANT SAFETY INSTRUCTIONS

Before you work on any equipment, be aware of the hazards involved with electrical circuitry and be familiar with standard practices for preventing accidents. Read the installation instructions before using, installing, or connecting the system to the power source. Use the statement number provided at the end of each warning statement to locate its translation in the translated safety warnings for this device.

SAVE THESE INSTRUCTIONS



Warning **Statement 1004**—Installation Instructions

Read the installation instructions before using, installing, or connecting the system to the power source.



Warning Statement 1005—Circuit Breaker

This product relies on the building's installation for short-circuit (overcurrent) protection. Ensure that the protective device is rated not greater than: 20 A, 120 V, and 16 A, 250 V



Warning Statement 1015—Battery Handling

To reduce risk of fire, explosion or leakage of flammable liquid or gas:

- Replace the battery only with the same or equivalent type recommended by the manufacturer.
 - Do not dismantle, crush, puncture, use sharp tool to remove, short external contacts, or dispose of in fire.
 - Do not use if battery is warped or swollen.
 - Do not store or use battery in a temperature $> 60^{\circ}$ C.
 - Do not store or use battery in low air pressure environment < 69.7 kPa.
-



Warning Statement 1017—Restricted Area

This unit is intended for installation in restricted access areas. Only skilled, instructed, or qualified personnel can access a restricted access area.



Warning Statement 1021—SELV Circuit

To avoid electric shock, do not connect SELV circuits to telephone-network voltage (TNV) circuits. LAN ports contain SELV circuits, and WAN ports contain TNV circuits. Some LAN and WAN ports both use RJ-45 connectors. Use caution when connecting cables.



Warning Statement 1024—Ground Conductor

This equipment must be grounded. To reduce the risk of electric shock, never defeat the ground conductor or operate the equipment in the absence of a suitably installed ground conductor. Contact the appropriate electrical inspection authority or an electrician if you are uncertain that suitable grounding is available.

**Warning Statement 1028—More Than One Power Supply**

This unit might have more than one power supply connection. To reduce risk of electric shock, remove all connections to de-energize the unit.

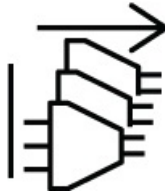
**Warning Statement 1029—Blank Faceplates and Cover Panels**

Blank faceplates and cover panels serve three important functions: they reduce the risk of electric shock and fire, they contain electromagnetic interference (EMI) that might disrupt other equipment, and they direct the flow of cooling air through the chassis. Do not operate the system unless all cards, faceplates, front covers, and rear covers are in place.

**Warning Statement 1030—Equipment Installation**

Only trained and qualified personnel should be allowed to install, replace, or service this equipment.

**Warning Statement 1040—Product Disposal**

Ultimate disposal of this product should be handled according to all national laws and regulations.

**Warning Statement 1074—Comply with Local and National Electrical Codes**

To reduce risk of electric shock or fire, installation of the equipment must comply with local and national electrical codes.

Position the Chassis

See [Desktop-Mount the Chassis, on page 32](#) for information on desktop-mounting the chassis.

Figure 24: Desk Top Mount the Chassis

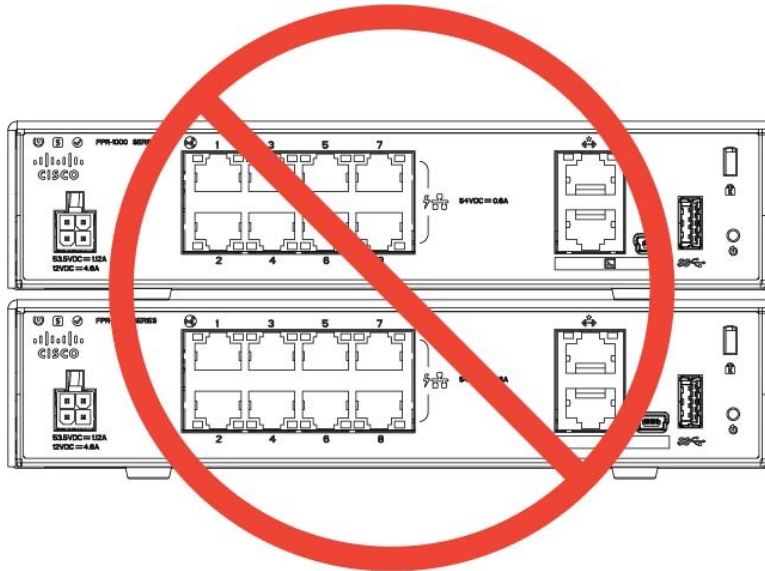

Caution Do not stack the chassis on top of another chassis. If you stack the units, they will overheat, which causes the units to power cycle.

Whether positioning the chassis on a desktop, on a closet shelf, or mounting it on a wall, consider the following:

- Be sure to choose an area where the chassis is out of the way to make sure it is not bumped or accidentally dislodged. The chassis has feet on the bottom so it does not sit flush where placed, thus allowing proper air circulation through and around it. Make sure that the chassis is not tightly enclosed or crowded by other objects that might impede proper circulation.
- Choose a location that lets you easily bring the power cord and Ethernet and console cables to the chassis, with plenty of slack and yet tucked away, so they cannot be inadvertently unplugged.

Safety Recommendations

Observe these safety guidelines:

- Keep the area clear and dust free before, during, and after installation.
- Keep tools away from walkways, where you and others might trip over them.
- Do not wear loose clothing or jewelry, such as earrings, bracelets, or chains that could get caught in the chassis.
- Wear safety glasses if you are working under any conditions that might be hazardous to your eyes.
- Do not perform any action that creates a potential hazard to people or makes the equipment unsafe.
- Never attempt to lift an object that is too heavy for one person.

Maintain Safety with Electricity



Warning Before working on a chassis, be sure the power cord is unplugged.

Read the [Regulatory and Compliance Information](#) document before installing the chassis.

Follow these guidelines when working on equipment powered by electricity:

- Before beginning procedures that require access to the interior of the chassis, locate the emergency power-off switch for the room in which you are working. Then, if an electrical accident occurs, you can act quickly to turn off the power.
- Do not work alone if potentially hazardous conditions exist anywhere in your work space.
- Never assume that power is disconnected; always check.
- Look carefully for possible hazards in your work area, such as moist floors, ungrounded power extension cables, frayed power cords, and missing safety grounds.
- Use the chassis within its marked electrical ratings and product usage instructions.
- The chassis is equipped with an AC-input power supply, which is shipped with a three-wire electrical cord with a grounding-type plug that fits into a grounding-type power outlet only. Do not circumvent this safety feature. Equipment grounding should comply with local and national electrical codes.

Prevent ESD Damage

ESD occurs when electronic components are improperly handled, and it can damage equipment and impair electrical circuitry, which can result in intermittent or complete failure of your equipment.

Always follow ESD-prevention procedures when removing and replacing components. Ensure that the chassis is electrically connected to an earth ground. Wear an ESD-preventive wrist strap, ensuring that it makes good skin contact. Connect the grounding clip to an unpainted surface of the chassis frame to safely ground ESD voltages. To properly guard against ESD damage and shocks, the wrist strap and cord must operate effectively. If no wrist strap is available, ground yourself by touching the metal part of the chassis.

For safety, periodically check the resistance value of the antistatic strap, which should be between one and 10 megohms.

Site Environment

You can place the chassis on a desktop, on the wall, or in a rack. The location of the chassis and the layout of the equipment rack or wiring room are extremely important for proper system operation. Placing equipment too close together with inadequate ventilation and inaccessible panels can cause system malfunctions and shutdowns. Improper placement can also make it difficult for you to access the chassis for maintenance.

**Warning**

Under no circumstances should you stack one chassis on top of one another. This disrupts cooling air flow to the chassis and causes damage to the hardware.

See [Hardware Specifications, on page 14](#) for information about physical specifications.

To avoid equipment failures and reduce the possibility of environmentally caused shutdowns, plan the site layout and equipment locations carefully. If you are currently experiencing shutdowns or unusually high error rates with your existing equipment, these considerations may help you isolate the cause of failures and prevent future problems.

Site Considerations

Considering the following helps you plan an acceptable operating environment for the chassis, and avoid environmentally-caused equipment failures.

- Electrical equipment generates heat. Ambient air temperature might not be adequate to cool equipment to acceptable operating temperatures without adequate circulation. Make sure that the room in which you operate your system has adequate air circulation.
- Ensure that the chassis cover is secure. The chassis is designed to allow cooling air to flow effectively within it. An open chassis allows air leaks, which may interrupt and redirect the flow of cooling air from the internal components.
- Always follow ESD-prevention procedures to avoid damage to equipment. Damage from static discharge can cause immediate or intermittent equipment failure.

Power Supply Considerations

See [Features, on page 1](#) and [Hardware Specifications, on page 14](#) for more detailed information about the power supply in the chassis.

When installing the chassis, consider the following:

- Check the power at the site before installing the chassis to ensure that it is free of spikes and noise. Install a power conditioner, if necessary, to ensure proper voltages and power levels in the appliance-input voltage.
- Install proper grounding for the site to avoid damage from lightning and power surges.
- The chassis does not have a user-selectable operating range. Refer to the label on the chassis for the correct appliance input-power requirement.
- Several styles of AC-input power supply cords are available for the chassis; make sure that you have the correct style for your site.
- Install an uninterruptible power source for your site, if possible.

Rack Configuration Considerations

See [Rack-Mount the Chassis, on page 35](#) for the procedure for rack-mounting the chassis.

Consider the following when planning a rack configuration:

- If you are mounting a chassis in an open rack, make sure that the rack frame does not block the intake or exhaust ports.
- If your rack includes closing front and rear doors, the doors must have 65 percent open perforated area evenly distributed from top to bottom to permit adequate airflow.
- Be sure enclosed racks have adequate ventilation. Make sure that the rack is not overly congested as each chassis generates heat. An enclosed rack should have louvered sides and a fan to provide cooling air.
- In an enclosed rack with a ventilation fan in the top, heat generated by equipment near the bottom of the rack can be drawn upward and into the intake ports of the equipment above it in the rack. Ensure that you provide adequate ventilation for equipment at the bottom of the rack.
- Baffles can help to isolate exhaust air from intake air, which also helps to draw cooling air through the chassis. The best placement of the baffles depends on the airflow patterns in the rack. Experiment with different arrangements to position the baffles effectively.



CHAPTER 3

Mount the Chassis

- [Unpack and Inspect the Chassis, on page 31](#)
- [Desktop-Mount the Chassis, on page 32](#)
- [Wall-Mount the Chassis, on page 32](#)
- [Rack-Mount the Chassis, on page 35](#)

Unpack and Inspect the Chassis



Note The chassis is thoroughly inspected before shipment. If any damage occurred during transportation or any items are missing, contact your customer service representative immediately. Keep the shipping container in case you need to send the chassis back due to damage.

See [Package Contents, on page 8](#) for a list of what shipped with the chassis.

- Step 1** Remove the chassis from its cardboard container and save all packaging material.
- Step 2** Compare the shipment to the equipment list provided by your customer service representative. Verify that you have all items.
- Step 3** Check for damage and report any discrepancies or damage to your customer service representative. Have the following information ready:
- Invoice number of shipper (see the packing slip)
 - Model and serial number of the damaged unit
 - Description of damage
 - Effect of damage on the installation
-

Desktop-Mount the Chassis

You can mount the chassis on a desktop by placing it on a desk in a horizontal position. Make sure there are no blockages or obstructions within one inch of the top of the chassis or within .5 inches of the sides and back, so that nothing interferes with cooling. Do not remove the rubber feet included with the chassis. They are also needed for proper cooling.

Figure 25: Desk Top Mount the Chassis

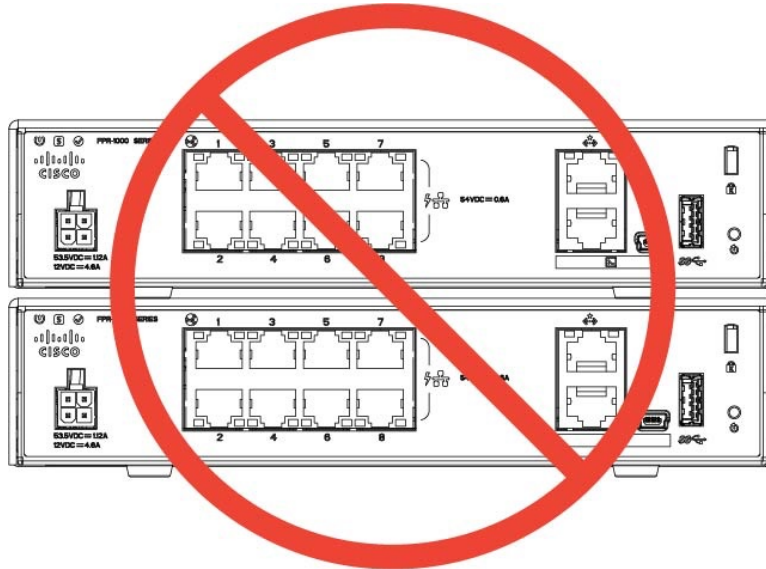

Caution Do not stack one chassis on top of another chassis. If you stack the units, they will overheat, which causes the units to power cycle.

What to do next

See [Install the FIPS Opacity Shield](#), on page 45 if you need to install a FIPS opacity shield.

Install the cables according to your default software configuration as described in the [Cisco Firepower 1010 Getting Started Guide](#).

Wall-Mount the Chassis

You can purchase an optional wall-mount kit. You can wall-mount the chassis left-, right-, or rear panel-side up. You can use the wall-mount bracket to mark the holes for mounting it on the wall. The wall-mount bracket is 7.682 x 6 inches. You need to make two level marks on the wall where you want to hang the chassis. For vertical orientation (rear panel up), the holes should be 6.826 inches apart. For side to side orientation, the holes should be 5.154 inches apart.

The wall-mount kit (part number 69-100647-01) contains the following items:

- Wall-mount bracket (part number 700-118506-01)

- Three Phillips M3 x 6-mm screws (part number 48-0460-01)
- Two Phillips #6 x 1¼-inch screws (part number 48-2289-01)
- One #8 wall anchor kit with screws (part number 51-4718-01)

Follow these steps to mount your chassis on a wall.

- Step 1** Choose an orientation (left-, right-, or rear panel-side up) and a location on the wall for the chassis.
- Step 2** Use a pencil, ruler, and level to mark locations for the two mounting screws (#6 x 1¼ inch). You can use the wall-mount bracket itself to mark either the top holes or the side holes.

Figure 26: Wall-Mount Bracket

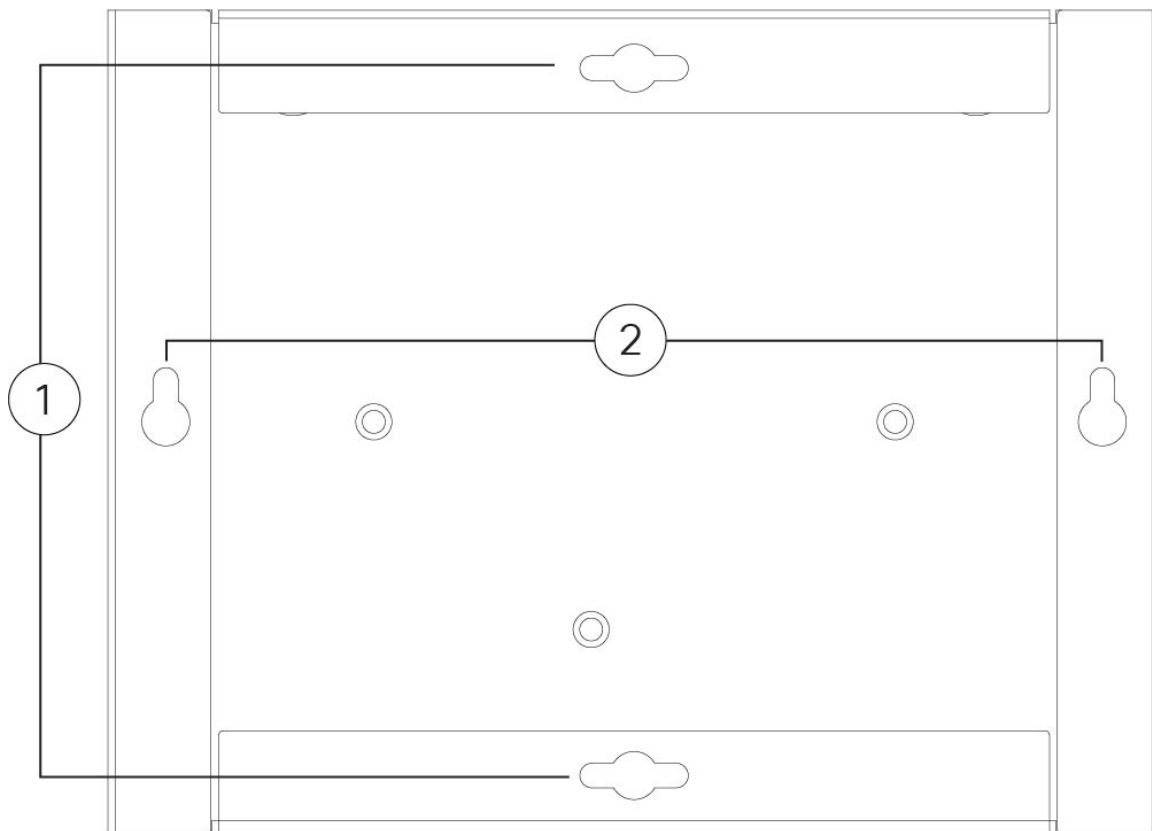

1	Horizontal mounting	2	Vertical mounting
----------	---------------------	----------	-------------------

- Step 3** Attach the wall-mount bracket to the chassis using the three Phillips M3 x 6-mm screws.

Figure 27: Attach the Wall-Mount Bracket to the Chassis

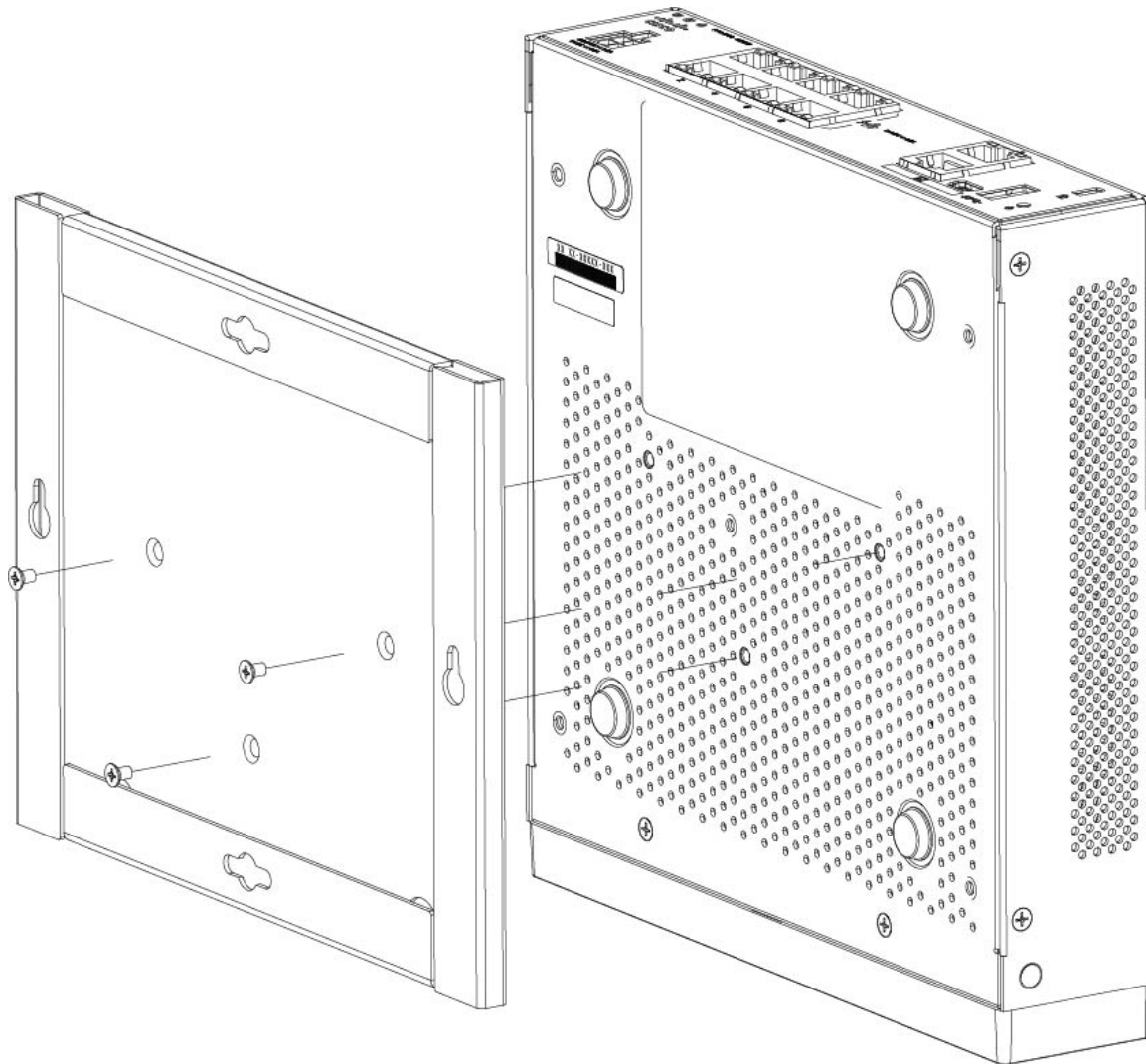

Step 4 Use the two #6 x 1/4-inch screws to drill into a stud, or use the anchors (#8 wall screw) from the dry-wall kit to hang it into dry wall.

If you are mounting the chassis onto something other than drywall, such as wood or sheet metal, anchors may not be required.

Step 5 Drill a hole into the wall at each mark that you made in Step 2.

These holes should be slightly smaller in diameter than anchors if you are using them. The recommended drill hole size is 3/16 inches.

Step 6 Insert the anchors into the holes if needed, and be sure they are properly seated.

Step 7 Fasten each screw into its anchor until it protrudes about 1/4 inch.

Step 8 Pick up the chassis, align the screws in the anchors with the holes in the bottom of the wall-mount bracket, move the chassis toward the wall until the screw heads are in the wall-mount bracket, and then slide it down until it rests on the screws.

Caution Do not mount the chassis with the rear panel facing downward. This orientation is not supported.

Step 9 To uninstall the chassis from the wall mount, slide the wall-mounted chassis from the wall, and remove the three screws from the bottom of the chassis.

What to do next

If you are installing a FIPS cover on the chassis, follow the steps in [Install the FIPS Opacity Shield](#), on page 45.

Install the cables according to your default software configuration as described in the [Cisco Firepower 1010 Getting Started Guide](#).

Rack-Mount the Chassis

The rack-mount kit (800-107605-01) contains the following items:



Note There are two sets of four screws that you can use to secure the chassis to your rack. Chose the screws that fit your rack.

- Rack shelf (part number 700-122662-01)
 - Two sliding rack trays (part number 800-107648-01)
 - Two cable guides (part number 700-122664-01)
 - Twelve Phillips M3 x 7-mm screws (part number 48-1921-01); use these screws to install the cable guides and to secure the rack shelf onto the chassis.
 - Four Phillips 12-24 x 0.75-inch screws (part number 48-0440-01); depending on your rack type, use these screws to secure the sliding-rack tray to your rack.
 - Four Phillips 10-32 x 0.75-inch screws (part number 48-0441-01); depending on your rack type, use these screws to secure the sliding-rack tray to your rack.
-

Step 1 Install the cable guides on the rack shelf:

Figure 28: Attach the Cable Guides to the Rack Shelf Flange

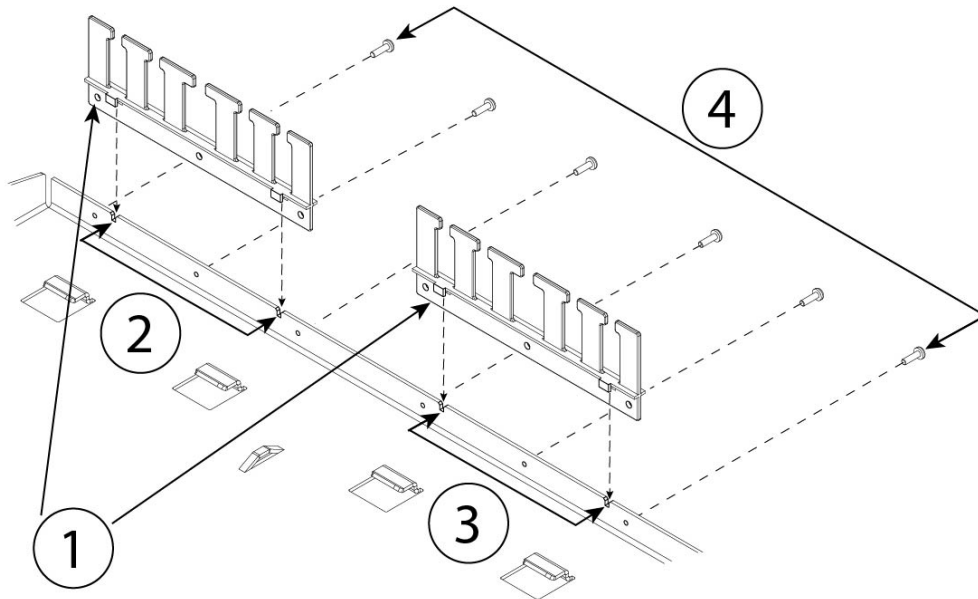

1	Two cable guides (part number 700-122664-01)	2	Left cable guide rack shelf cutouts
3	Right cable guide rack shelf cutouts	4	Six of the twelve Phillips M3 x 7-mm screws (part number 48-1921-01)

- a) Align the cable guides with the cutouts on the rack shelf flange (see figure above).
- b) At the rear of the rack shelf, attach the left and right cable guides using six of the twelve Phillips M3 x 7-mm screws (part number 48-1921-01).

Note Drive the screws in while facing the back of the rack shelf.

- c) Set the rack shelf aside. Continue with Step 2 to install the sliding rack tray on the chassis.
The figure in Step 8 shows the rack shelf with the cable guides attached.

Step 2 Place the chassis with the top facing down on a large, stable work area.

Step 3 Invert the sliding rack tray and position it on the chassis. You can mount the chassis with the front or rear panel facing front.

Figure 29: Install the Sliding Rack Tray on the Chassis

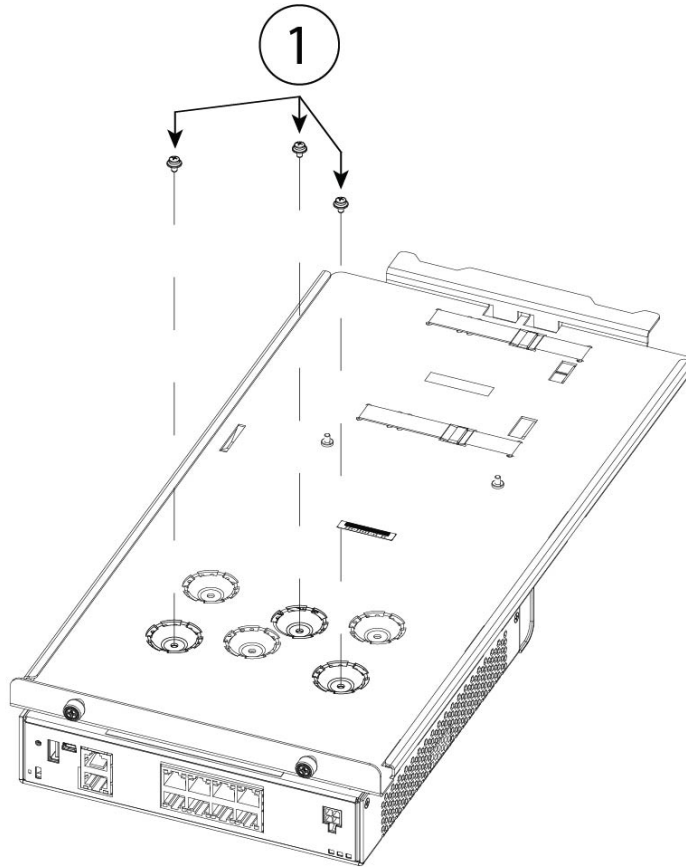

1	Three of the twelve M3 x 7-mm screws (part number 48-1921-01)	—
----------	---	---

- Step 4** Adjust the position of the chassis and the sliding rack tray until the three mounting holes in the dimples in the bottom of the sliding rack tray are aligned with the mounting holes in the bottom of the chassis.
- Step 5** Tighten the three M3 x 7-mm screws to lock the chassis into place on the sliding rack tray (see the figure above).
- Step 6** Carefully turn the sliding rack tray right-side up.
- Step 7** Install the power supply in the sliding rack tray behind the chassis.

Figure 30: Install the Power Supply in the Sliding Rack Tray

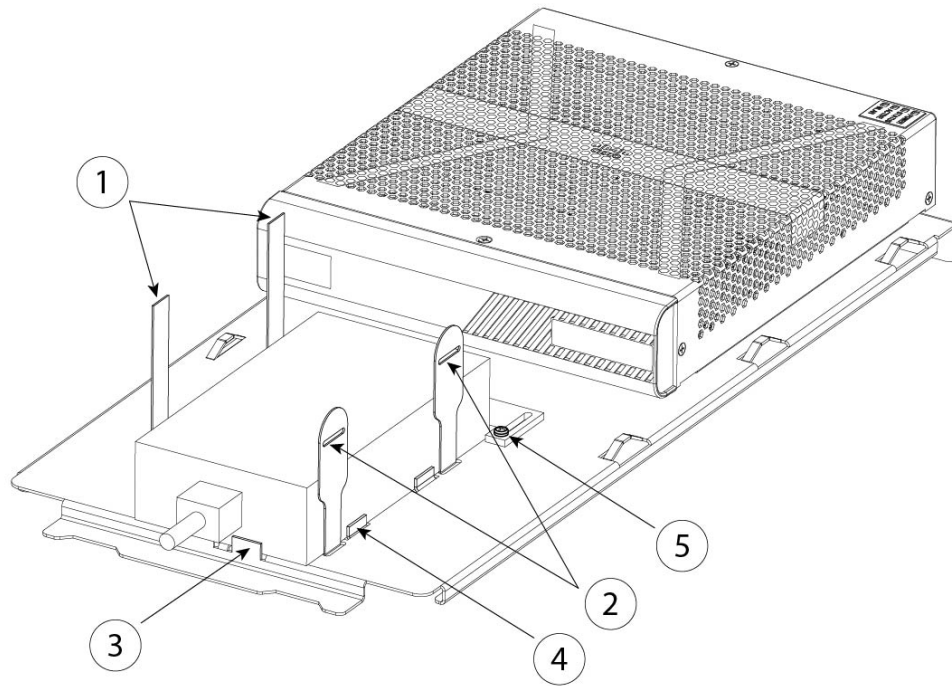

1	Velcro straps for the power supply	2	Velcro straps for the power supply
3	Power supply stop	4	Power supply stop
5	Rear sliding stop and screw (one of two screws on the sliding stop)		—

- a) Loosen the Velcro straps and place the power supply on the sliding rack tray behind the chassis. Make sure the AC inlet cord faces the rear.
- b) Align the power supply to the side and rear stops.
If the rear sliding stop is not touching the power supply, loosen the two screws, slide the stop up to touch the power supply, and then retighten screws.
- c) Re-engage the Velcro straps and tighten them to secure the power supply.

Figure 31: Tighten the Velcro Straps

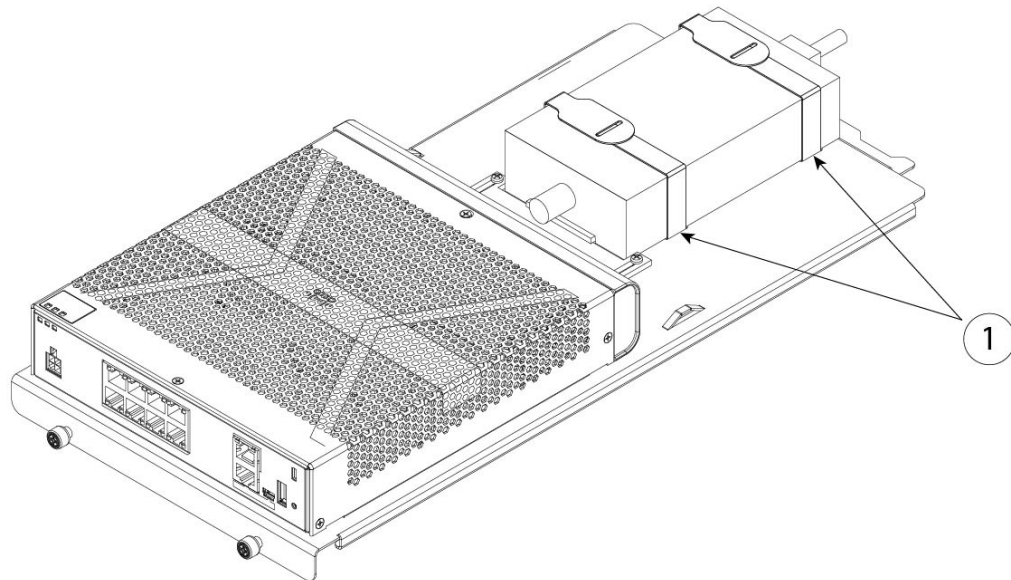

1	Velcro straps tightened over power supply	—
----------	---	---

Step 8 Slide the sliding rack tray into the rack shelf.

Figure 32: Slide the Sliding Rack Tray Into the Rack Shelf

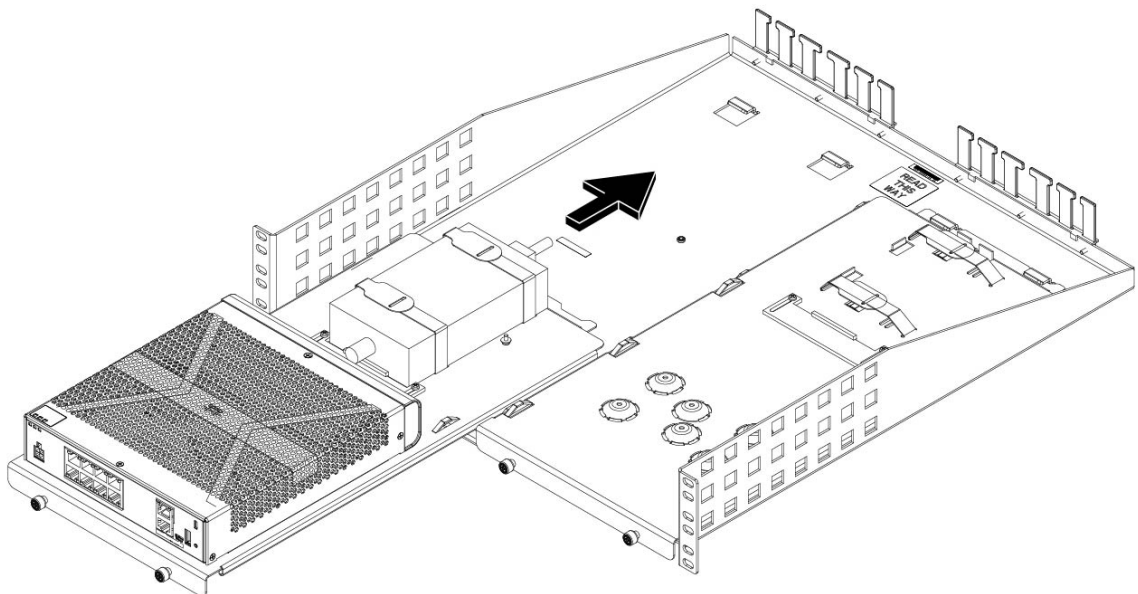

Step 9 The chassis is now installed in the sliding rack tray, which is installed in the rack shelf. Repeat Steps 1 through 8 to install a second chassis. Use the second sliding rack tray and remaining three M3 x 7-mm screws to install a second chassis to the sliding rack tray and then onto the rack shelf (see Step 3).

Figure 33: Completed Sliding Rack Tray in Rack Shelf Installation

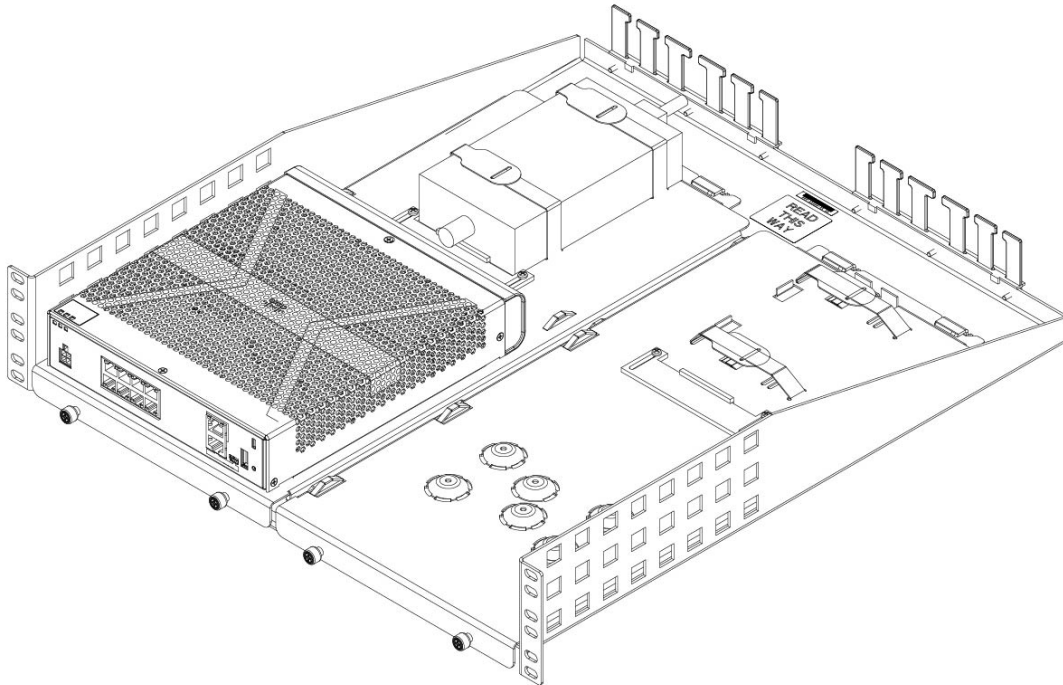

Step 10 Install the rack shelf into your rack using the correct screws (12-24 x 0.75 inch or 10-32 x 0.75 inch) from the rack-mount kit that fit your rack type.

You can now attach your power supply cord and run it through the cable guides.

What to do next

Install the cables according to your default software configuration as described in the [Cisco Firepower 1010 Getting Started Guide](#).



CHAPTER 4

Connect to the Console Port

- [Connect to the Console Port with Microsoft Windows, on page 41](#)
- [Connect to the Console Port with Mac OS X, on page 43](#)
- [Connect to the Console Port with Linux, on page 43](#)

Connect to the Console Port with Microsoft Windows

You must install a USB device driver the first time a Microsoft Windows-based PC is connected to the USB console port on the chassis, otherwise the connection fails.

To uninstall the driver, use the Add Remove Programs utility or the Setup-exe program.



Note Disconnect the console terminal before uninstalling the driver.

Step 1 Obtain the appropriate driver (Cisco_usbconsole_driver_X_X_zip, where X is a revision number) for your model from the Cisco [Download Software](#) site, USB Console Software category.

Note The download site redirects you to a router download section where the drivers are also applicable to Firepower products. The drivers are OS-specific and not tied to the vendor of the console cable manufacturer.

Step 2 Install the driver.

Step 3 Connect a 5-pin USB Mini B to the console port as shown in the following figure.

Figure 34: Console Port Connection

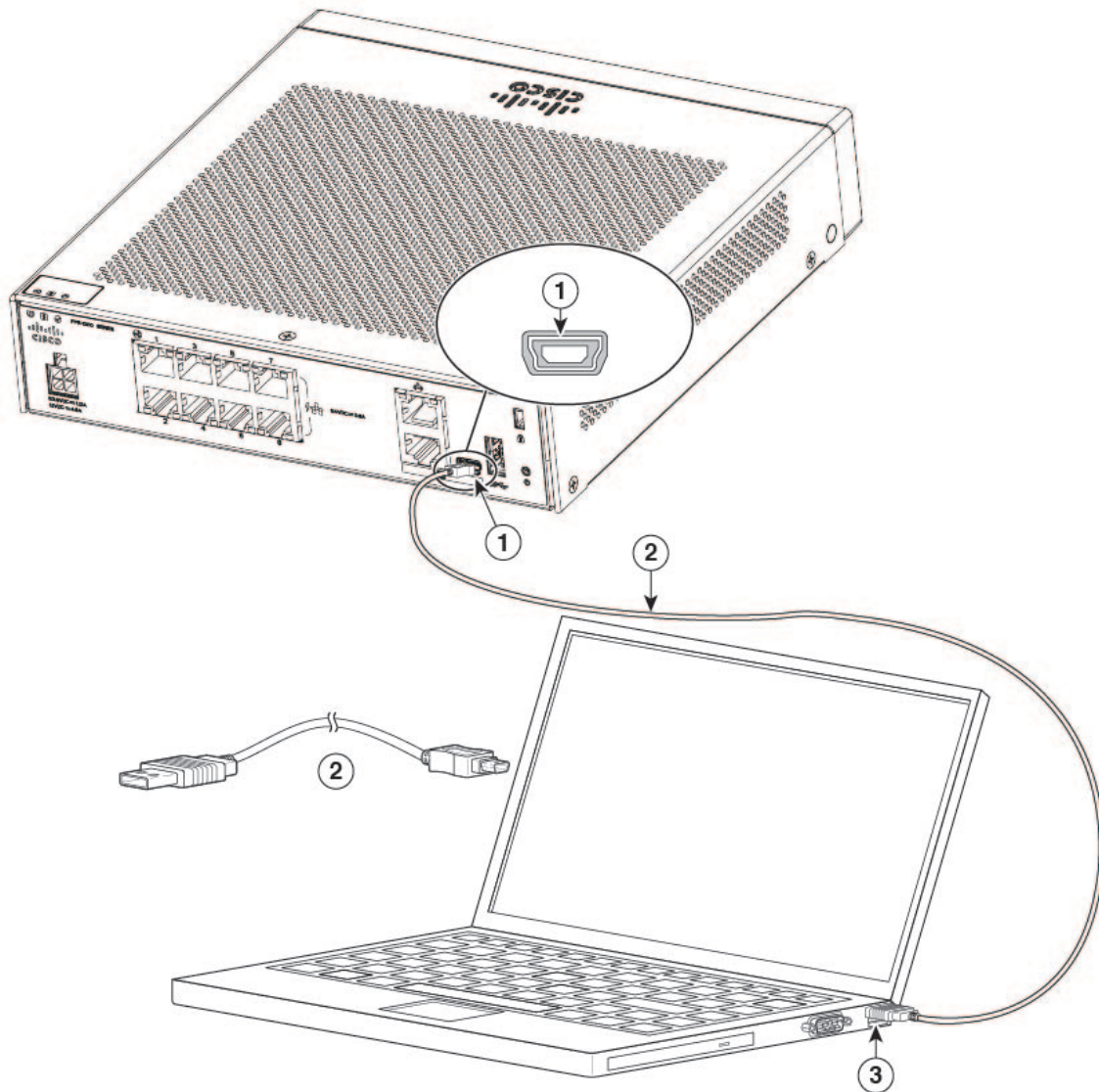

1	USB Mini B console port	2	USB Mini B to USB Type A console cable
3	USB Type A		—

Step 4 Connect the end of the cable with the DB-9 connector (or USB Type A) to the terminal or PC. If your terminal or PC has a console port that does not accommodate a DB-9 connector, you must provide an appropriate adapter for that port. The LED for the console port turns green and within a few moments the Found New Hardware Wizard appears.

Step 5 Follow the instructions to complete the driver installation.

Step 6 To communicate with the chassis, start a terminal emulator application. This software should be configured with the following parameters:

- 9600 baud
- 8 data bits

- no parity
- 1 stop bit
- no flow control

Connect to the Console Port with Mac OS X

Follow these steps to connect a Mac OS X system USB port to the console using the built-in OS X Terminal utility, or alternatively you can use a separate terminal emulator application.

Step 1 Use the Finder to go to **Applications > Utilities > Terminal**.

Step 2 Connect the OS X USB port to the chassis.

Step 3 Enter the following commands to find the OS X USB port number:

Example:

```
macbook:user$ cd /dev
macbook:user$ ls -ltr /dev/*usb*
crw-rw-rw- 1 root wheel 9, 66 Apr 1 16:46 tty.usbmodem1a21
DT-macbook:dev user$
```

Step 4 Connect to the USB port with the following command followed by the chassis USB port speed:

Example:

```
macbook:user$ screen /dev/tty.usbmodem1a21 9600
```

Step 5 Enter **Ctrl-a** followed by **d** to disconnect the OS X USB console from the Terminal window.

Connect to the Console Port with Linux

Follow these steps to connect a Linux system USB port to the console using the built-in Linux Terminal utility.

Step 1 Open the Linux Terminal window.

Step 2 Connect the Linux USB port to the chassis.

Step 3 Enter the following commands to find the Linux USB port number:

Example:

```
root@usb-suse# cd /dev
root@usb-suse /dev# ls -ltr *ACM*
crw-r--r-- 1 root root 188, 0 Jan 14 18:02 ttyACM0
root@usb-suse /dev#
```

Step 4 Connect to the USB port with the following command followed by the chassis USB port speed

Example:

```
root@usb-suse /dev# screen /dev/ttyACM0 9600
```

Step 5 To disconnect the Linux USB console from the Terminal window, enter **Ctrl-a** followed by **:** then **quit**.



CHAPTER 5

Installation, Maintenance, and Upgrade

- [Install the FIPS Opacity Shield](#) , on page 45

Install the FIPS Opacity Shield



Note Because the FIPS opacity shield covers the serial number on the chassis, the CO should copy the serial number and store it in a secure place. The serial number is needed when you call Cisco TAC. See [Serial Number and Digital Documentation Portal QR Code](#), on page 10 for the location of the serial number.



Note You can *only* install the FIPS opacity shield with the desktop mount or wall mount. The rack mount does not support the FIPS shield. See [Desktop-Mount the Chassis](#), on page 32 and [Wall-Mount the Chassis](#), on page 32 for more information.

Before you begin



Caution This procedure should be performed only by the Crypto Officer (CO).

You need the following to install the FIPS opacity shield:

- #1 Phillips head screwdriver
- The following items from the FIPS kit (part number 69-100649-01):
 - One FIPS opacity shield (part number 800-106088-01)
 - Three M3 x 66 mm (part number 48-0384-01) screws used to attach the FIPS opacity shield to the chassis
 - Nine Tamper Evidence Labels (TELs) (part number 47-25553-01)



Note The TELs are made of a special thin gauge vinyl with self-adhesive backing. Once the CO attaches them on the chassis, any attempt to open the chassis damages the TELs or the chassis cover. Because the TELs have nonrepeated serial numbers, the CO can inspect them for damage and compare them against the applied serial numbers to verify whether the chassis has been tampered with. TELs with curled corners, rips, and slices indicate tampering. The word “FIPS” or “OPEN” may appear if the label has been peeled back.

- Step 1** Copy the serial number and store in a secure place.
- Step 2** If the chassis is mounted on a wall, uninstall it by following Steps 9-10 in [Wall-Mount the Chassis, on page 32](#).
- Step 3** Install the FIPS cover by holding the chassis right-side up and sliding the chassis into the FIPS cover front panel first.

Figure 35: Install Chassis into FIPS Cover

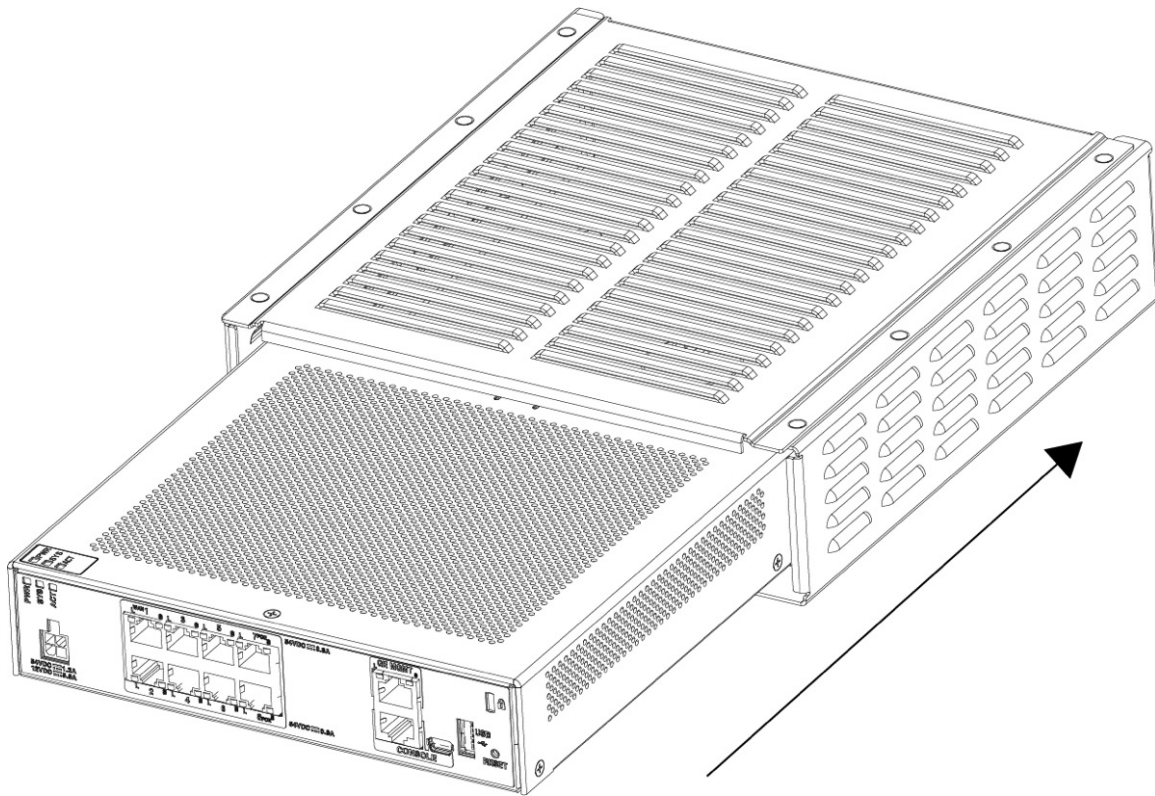

- Step 4** Turn the chassis with the FIPS cover installed over and install the three screws.

Figure 36: Install Screws on the Bottom of the FIPS Cover

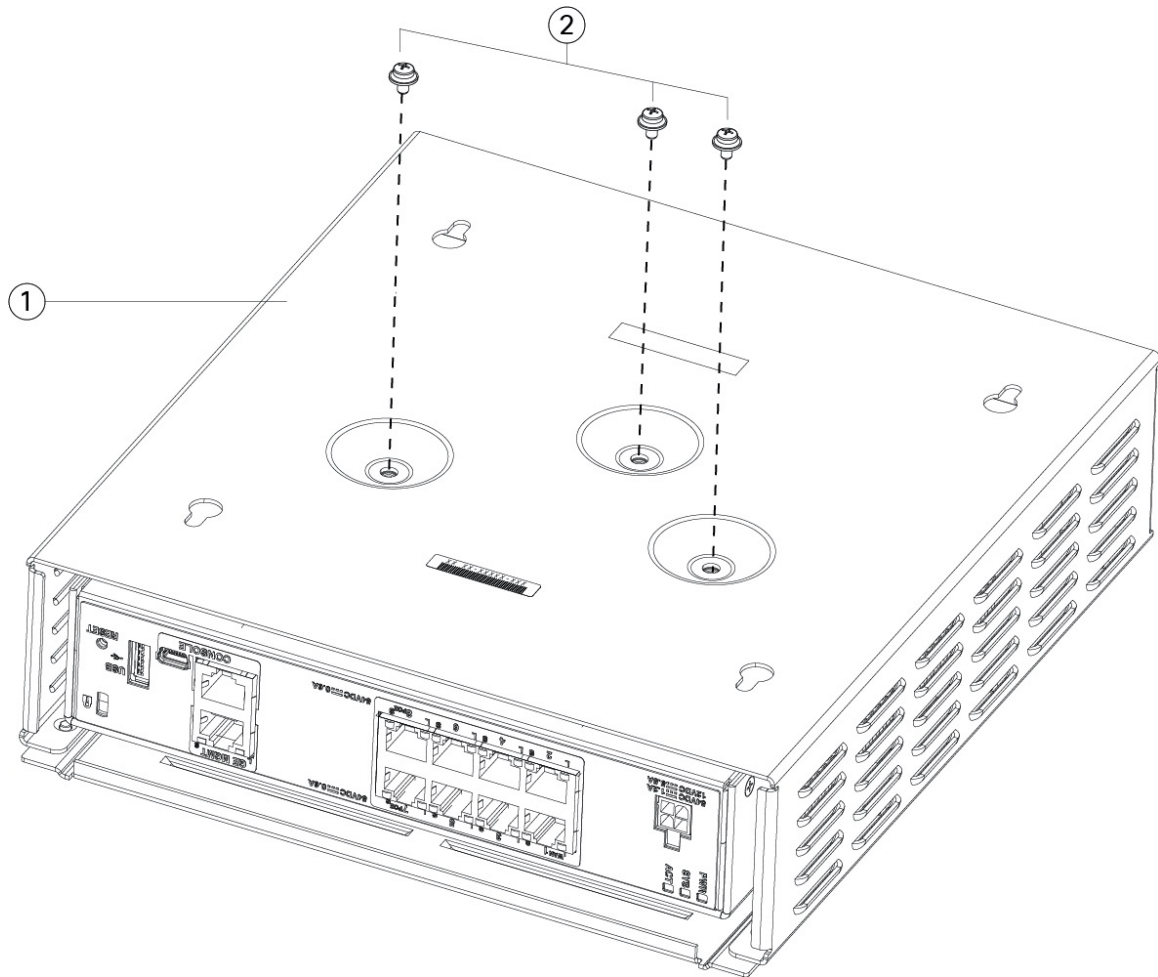

1	FIPS opacity shield	2	Three M3 x 66 mm Phillips screws
---	---------------------	---	----------------------------------

Step 5 Before you attach the TELs, clean the chassis and FIPS cover of any grease, dirt, or oil with alcohol-based cleaning pads.

Step 6 Attach four of the TELs, three on the bottom of the chassis over the screws and one on the front of the chassis. See the figure below for the correct placement. The figure shows the bottom of the chassis where you place three of the TELs. Allow the TELs to cure for a minimum of 12 hours.

Caution Any deviation in the placement of the TELs means the chassis is not in FIPS mode.

Figure 37: TELS Placement on the Rear Panel and Bottom of the FIPS Cover

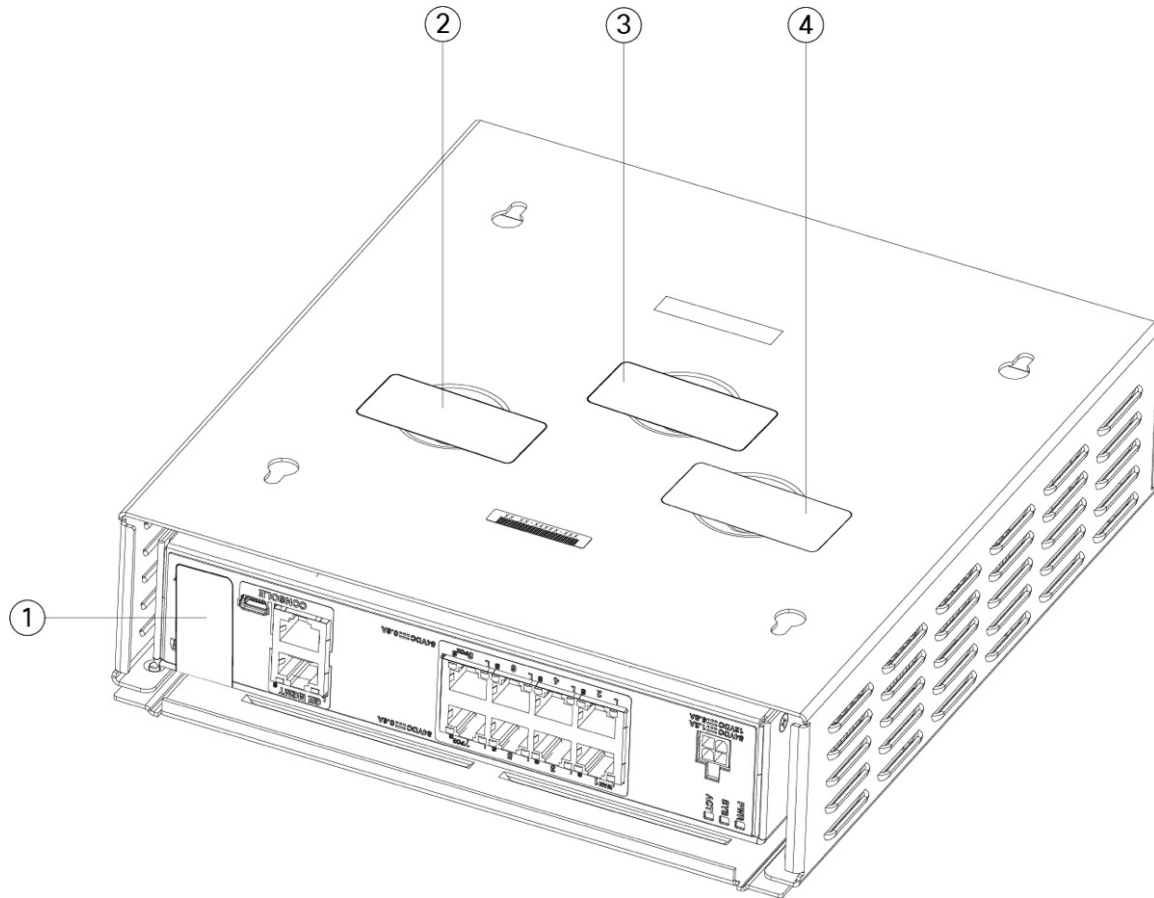

1	TEL 1 on the rear panel of the chassis	2	TEL 2 on the bottom left of the FIPS cover over the screw
3	TEL 3 on the bottom center of the FIPS cover over the screw	4	TEL 4 on the bottom right of the FIPS cover over the screw

- Step 7** Reinstall the chassis in the wall mount if you are using a mount. See [Wall-Mount the Chassis, on page 32](#) for the procedure.
- Step 8** Attach the power cable to the chassis and connect it to an electrical outlet.
- Step 9** Press the power switch on the rear panel.
- Step 10** Check the power LED on the front panel. See [Status LEDs, on page 12](#) for a description of the power LED. Solid green indicates that the chassis is powered on.
- Step 11** Place the chassis in FIPS mode.

See the following procedures for how to place the chassis in FIPS mode:

- See the "Security Certifications Compliance" chapter in the your software version configuration guide for the procedure to enable FIPS mode.

- See the **fips enable** command in the [Cisco ASA Series Command Reference, A-H Commands](#) for the ASA procedure to enable FIPS mode.
-

What to do next

See the [Cisco Firepower 1010 Getting Started Guide](#) for further configuration information.

